

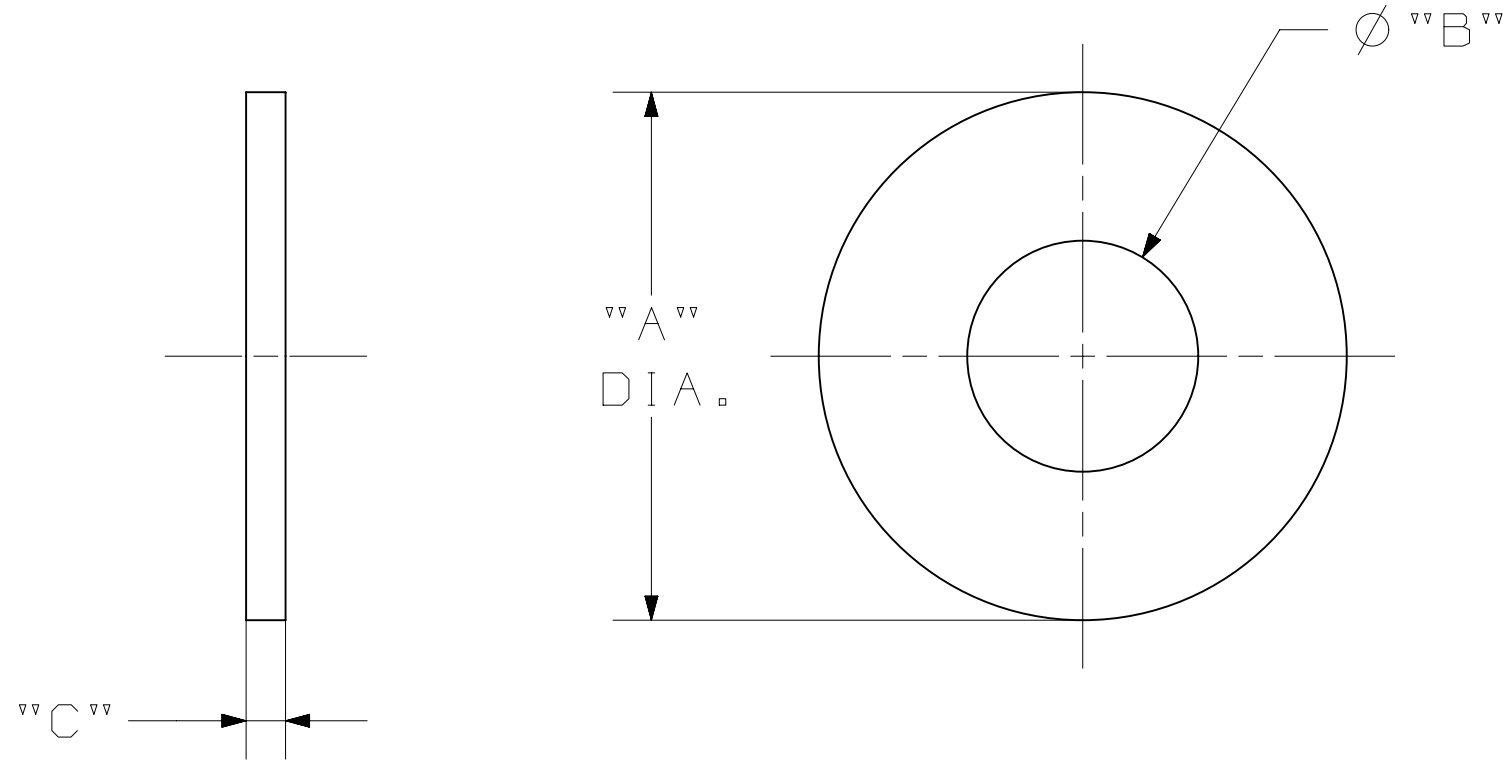

- NOTES -

1. MATERIAL: STEEL, HOT DIP GALV. PER ASTM A153 (LATEST REVISION).
2. CONFORMS TO ASME B18.22.1.

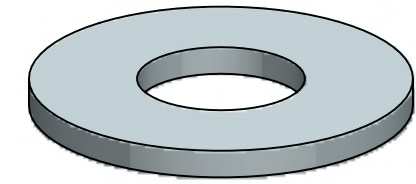
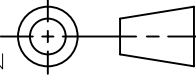
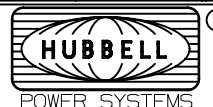

CATALOG #	"A"	"B"	"C"
400-285-144	3/4	5/16	16 GA.
PS6801 & 400-285-151	1	7/16	14 GA.
PS6802	1-1/4	9/16	14 GA.
PS6803 & 400-285-169	1-3/8	9/16	12 GA.
6805	1-3/4	11/16	11 GA.
6806	2	13/16	9 GA.
6808	2-1/2	1-1/16	8 GA.
PS6807	2-1/4	15/16	8 GA.

LATEST EC NO:		REV.	DATE	CHANGED BY	RESP ENGINEER
63150		B	11/30/15	WILSON	WILSON
				DO NOT SCALE THIS DWG	THIRD ANGLE PROJECTION 
				ISO DUAL DIMENSIONS IN=INCH, MM=MILLIMETER	
DRN BY:	DATE	TITLE:			SIZE
WILSON	04/20/11	ROUND WASHER			B
				 DWG NO: SA6801	

CONFIDENTIAL: THIS DRAWING AND ITS CONTENTS ARE CONFIDENTIAL AND THE EXCLUSIVE PROPERTY OF HUBBELL / A.B. CHANCE COMPANY. NO PUBLICATION, DISTRIBUTION OR COPIES MAY BE MADE WITHOUT WRITTEN CONSENT BY HUBBELL / A.B. CHANCE COMPANY. © 2001 HUBBELL/A.B. CHANCE. UNPUBLISHED - ALL RIGHTS RESERVED UNDER THE COPYRIGHT LAWS